

Techman Cobot - TM7S und TM5S

Reach and payload

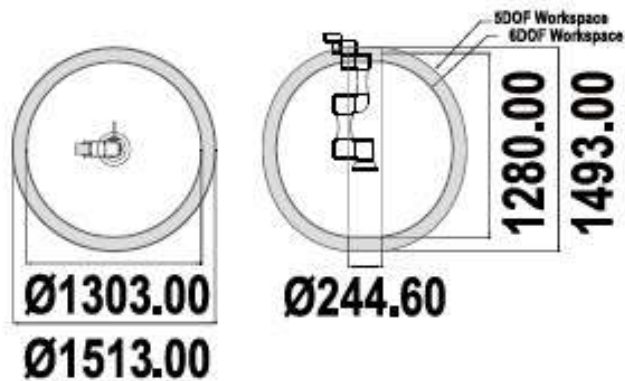

TM7S:



TM5S:

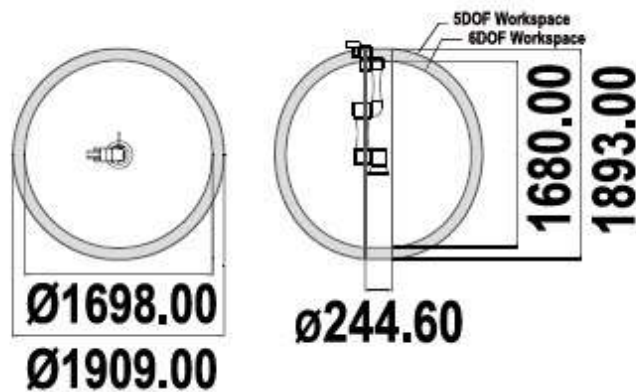

Accessories

A wide range of plug & play accessories such as grippers, screwdrivers or soldering equipment is available. Please contact us. We will work with you to develop a suitable solution through to a complete cell.





Specification TM7S and TM5S

Model		TM5S	TM7S
Weight		23,9 kg	22,9 kg
Maximum Payload		5 kg	7 kg
Reach		900 mm	700 mm
Maximum Speed		4,5 m/s	
Joint ranges	J1, J2, J4, J5, J6	+/- 360°	
	J3	+/- 158°	+/- 152°
Speed	J1, J2, J3	210°/s	
	J4, J5	225°/s	
	J6	450°/s	
Repeatability		+/- 0,03 mm	
Degree of Freedom		6 rotating joints	
I/O Control box		Digital in	16
		Digital out	16
		Analog in	2
		Analog out	2
I/O Tool Connectors		Digital in	3
		Digital out	3
		DO_0 (DO-0/AI) / DO_1 (DO-1/RS485+) / DO_2 (DO-2/RS485-)	
I/O Power Supply		24 V / 2,0 A for control box and 24 V / 1,5 A for tool	
IP Classification		IP54 robot arm, IP54 control box	
Typical power consumption		240 watts	
Cleanliness		ISO Class 3	
Temperature		0 - 50° C	
Power Supply		100-240 VAC, 50-60 Hz	
Communication		2x COM, 1xHDMI, 3xLAN, 2xUSB2.0, 4xUSB3.0	
Communikation		RS232, Ethernet, Modbus TCP/RTU (Master and Slave), PROFINET (optional), EtherNet/IP (optional)	
AI and Robot Vision			
AI Function		Classification, Object Detection, Segmentation, Anomaly Detection, AI OCR	
Application		Positioning, 10/20 Barcode Reading, OCR, Defect Detection, Measurement, Assembly Check	
Eye in Hand (camera built in)		Auto-focused color camera with SM resolution, Working distance 100 mm - 00	